

## HL710.2

anti-flood valve DN110 with 2 stainless steel flaps and manual blocking

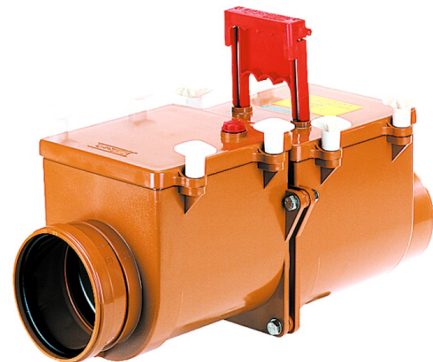

anti-flood valve DN110 with 2 automatic stainless steel flaps, cleaning eye and manual blocking.  
ATTENTION! New model - identifiable by sockets molded to the body. Models with screwed sockets have other spare parts - please contact HL!



### techn. drawing

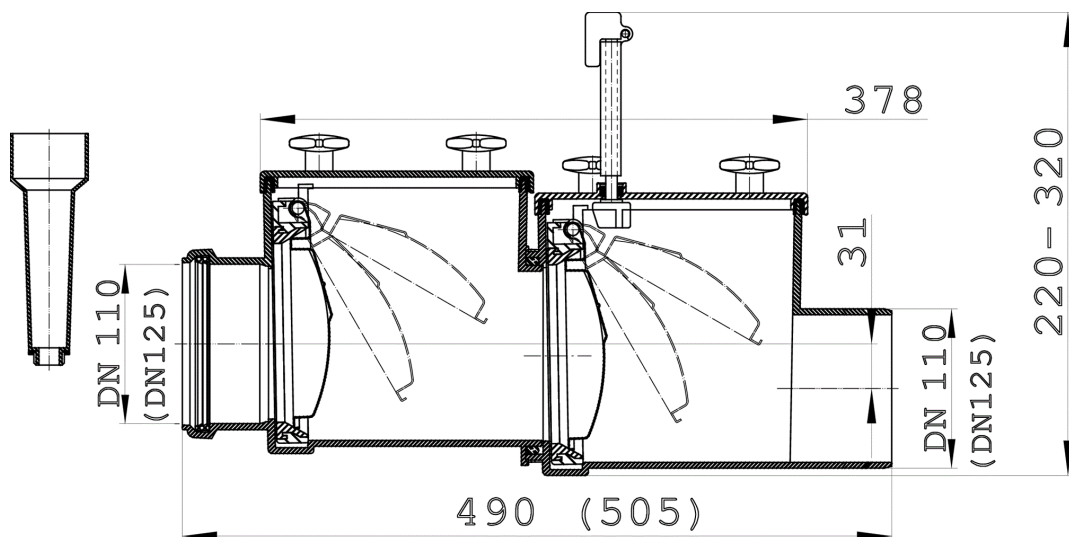

### TECHNICAL DATA

material	ABS	installation height	320 mm
dimension	DN110	grate frame	
capacity		grate	
weight	3,23	load class	

## HL715.2

anti-flood valve DN160 with 2 stainless steel flaps and manual blocking



anti-flood valve DN160 with 2 automatic stainless steel flaps, cleaning eye and manual blocking.  
ATTENTION! New model - identifiable by sockets molded to the body. Models with screwed sockets have other spare parts - please contact HL!

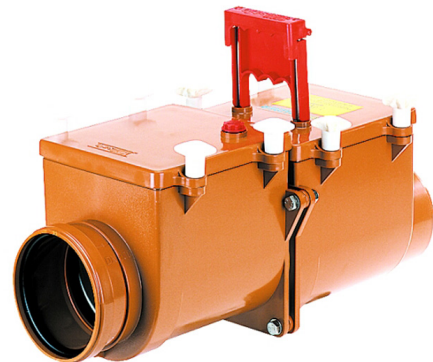

### techn. drawing

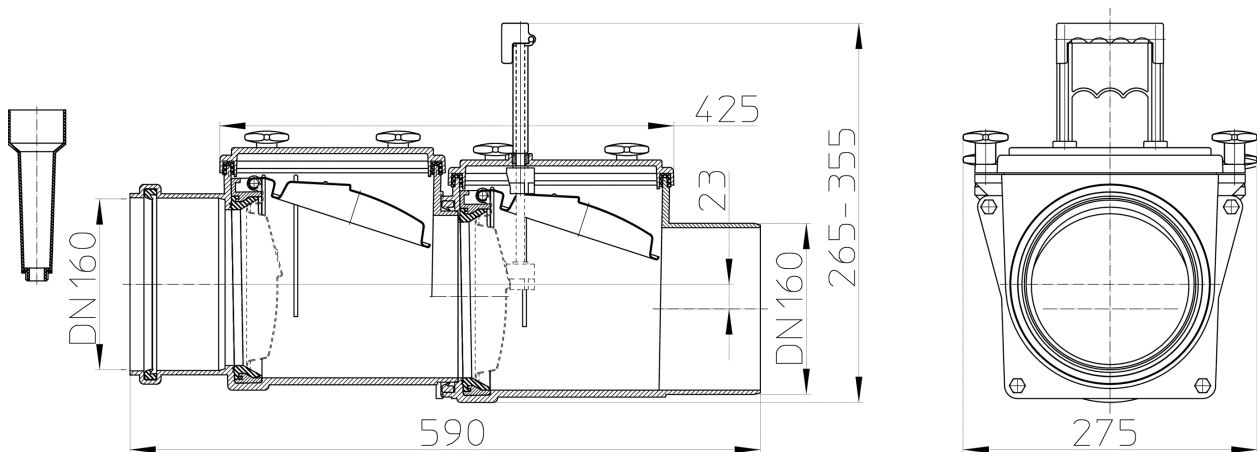

### TECHNICAL DATA

material	ABS	installation height	348 mm
dimension	DN160	grate frame	
capacity		grate	
weight	5,87	load class	
EAN	9003076971527	inlet	

## HL720.2

anti-flood valve DN200 with 2 stainless steel flap and manual blocking



anti-flood valve DN200 with 2 automatic stainless steel flaps, cleaning eye and manual blocking



### techn. drawing

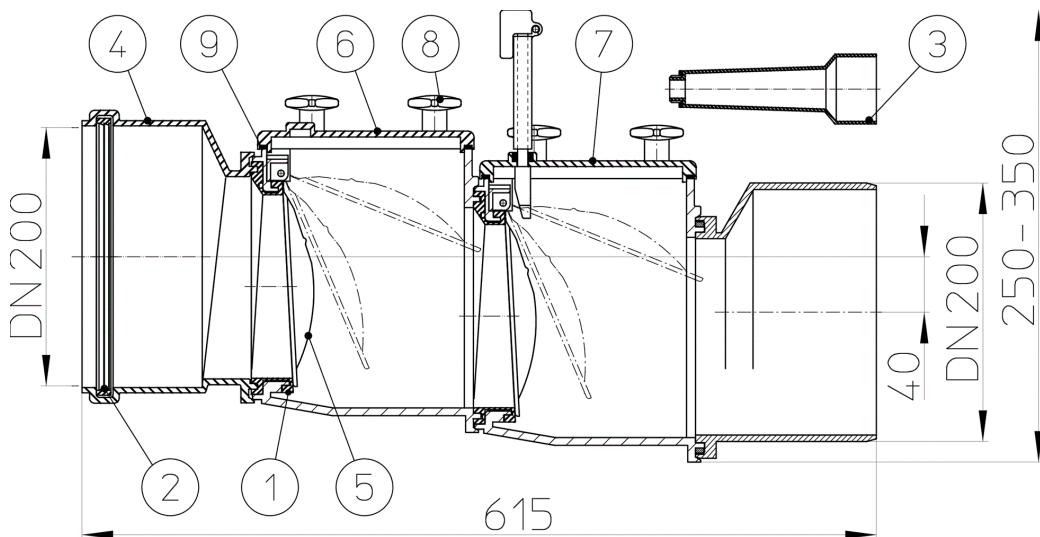

### TECHNICAL DATA

material	ABS	installation height	248 mm
dimension	DN200	grate frame	
capacity		grate	
weight	6,17	load class	