

HL62.1/1

flat-roof drain DN110 with clamping ring, heated (10-30W/230V)



flat-roof drain DN110 vertical with insulated drain body, flange with stainless steel clamping ring (- dress the membrane over the flange and clamp it - ready!), self regulating heating element (10 - 30 W / 230 V) and domed plastic grate d 180 mm. Comes with lot cover.



techn. drawing

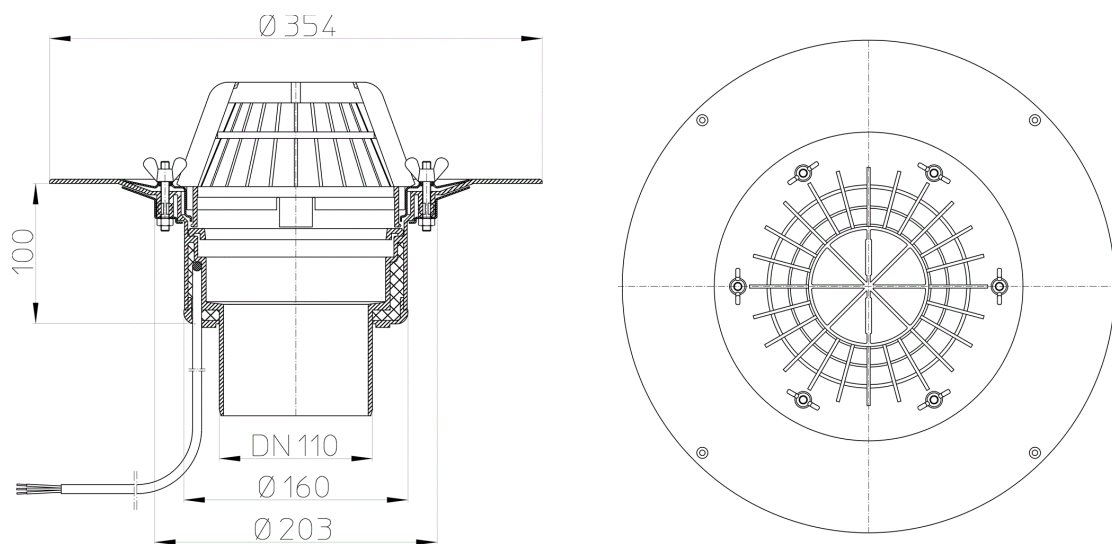

TECHNICAL DATA

material	PP	installation height	100 mm
dimension	DN110	grate frame	
capacity	10,7 l/s	grate	Laubfangkorb d 145 mm
weight	1,63	load class	

HL62.1/5

flat-roof drain DN160 with clamping ring, heated (10-30W/230V)



flat-roof drain DN160 vertical with insulated drain body, flange with stainless steel clamping ring (- dress the membrane over the flange and clamp it - ready!), self regulating heating element (10 - 30 W / 230 V) and domed plastic grate d 180 mm. Comes with lot cover.



techn. drawing

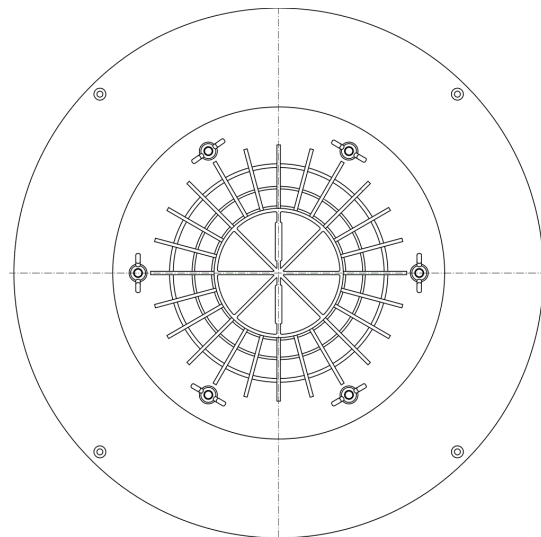
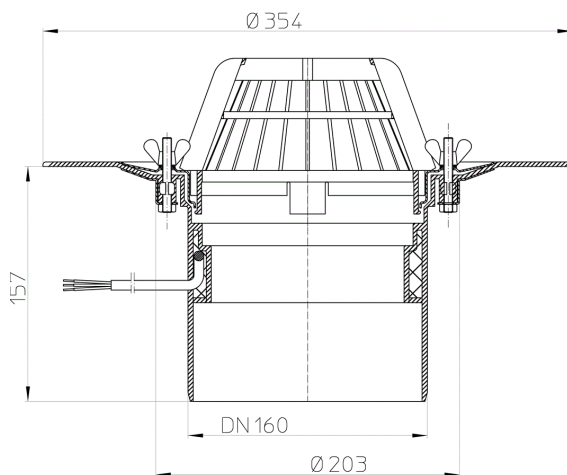

TECHNICAL DATA

material	PP	installation height	100 mm
dimension	DN160	grate frame	
capacity	14,1 l/s	grate	Laubfangkorb d 145 mm
weight	1,66	load class	